



User Manual

English

APC Smart-UPS[®] XL

SUA48RMXLBP3U

External Battery Pack

Introduction

About this Unit

The SUA48RMXLBP3U connects to the APC Smart-UPS XL. Together these units provide extended protection from utility power blackouts, brownouts, sags and surges from reaching your electronic equipment.

Unpack

Read the Safety Guide before installing the unit. The User Manual and Safety Guide are accessible on the supplied User Manuals CD and on the APC Web site, www.apc.com.

Inspect the unit upon receipt. Notify the carrier and dealer if there is damage.

The packaging is recyclable; save it for reuse or dispose of it properly.

Check the package contents:

- External Battery Pack with two battery modules installed
- Bezel
- Rail kit
- External Battery Pack literature kit containing:
 - Two brackets
 - Eight flathead screws
 - Product documentation
 - Smart-UPS® User Manuals CD
 - Safety information
 - Warranty information

The model and serial numbers for all units are located on the rear panel. See the small label with numbers and bar codes.

Specifications

Temperature Operating Storage	32° to 104° F (0° to 40° C) 5° to 113° F (-15° to 45° C) charge the battery module(s) every six months	This unit is designed for indoor use only. Select a location sturdy enough to handle the weight. Do not operate this unit where there is excessive dust or the temperature or humidity are outside the specified limits.
Maximum Elevation Operating Storage	10,000ft (3,000m) 50,000ft (15,240m)	
Humidity	0 to 95% relative humidity, non-condensing	
Weight	150 lbs (68 kg) with battery module 40 lbs (18 kg) without battery module 55 lbs (25 kg) each battery module	150 lbs (68 kg) 
Maximum Number of External Battery Packs Supported by the Smart-UPS XL	10	

Installation

Your external battery pack and UPS may vary in appearance from the examples depicted in this manual.

The battery pack and the battery modules are heavy. Remove the battery modules to lighten the unit during installation.

Install the Rails in the Rack

For details on rail installation refer to the instructions in the rail kit.

Install the Battery Pack in the Rack



The external battery pack is usually mounted below the UPS in the rack. If the UPS and the external battery pack are to be mounted in adjacent racks use an APC approved extension cable. Refer to the APC Web site, www.apc.com for ordering approved cables.

Refer to the UPS user manual for details on mounting the UPS and the external battery pack into a rack.

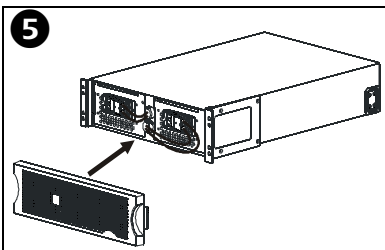
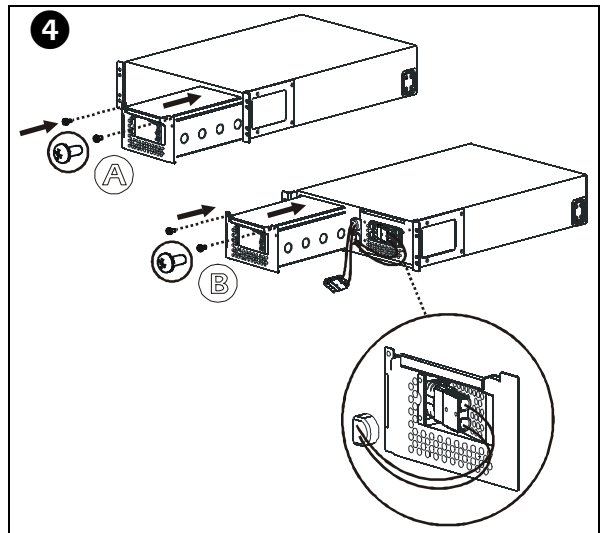
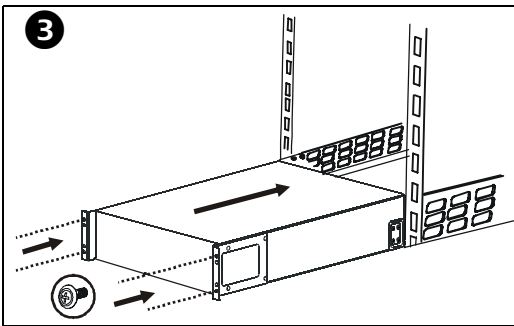
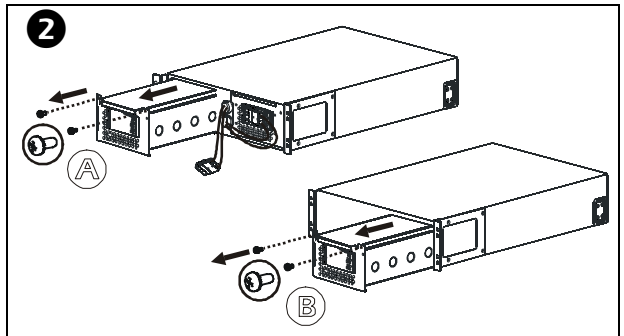
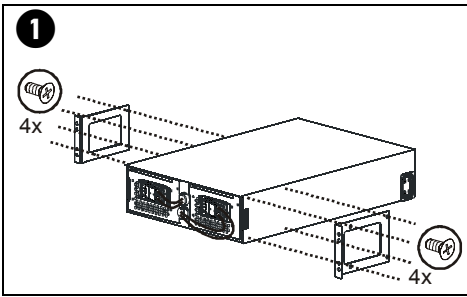

Connect the External Battery Pack(s)

- 1 Remove the two screws that secure the strain relief to the external battery connector.

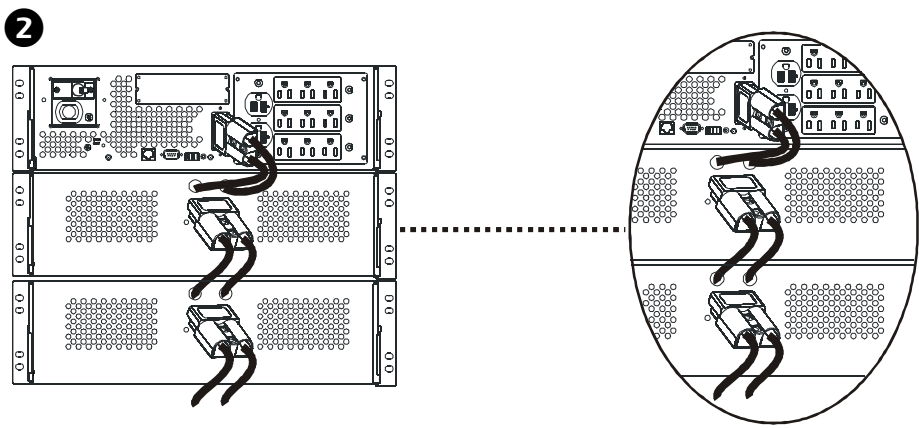
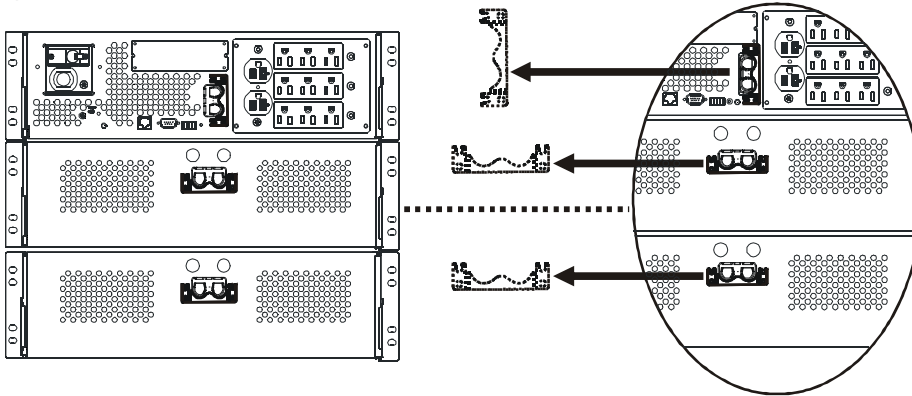

- 3 Reinstall the strain relief securing it with the two screws removed in step **1** above.

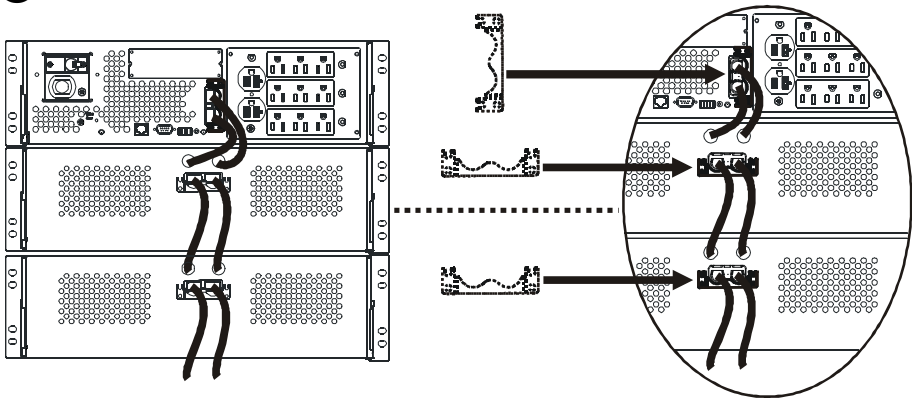

Setting the UPS to Recognize the Battery Pack(s)

Smart-UPS XL models must be programed for the appropriate number of external battery packs in one of two ways.

- PowerChute® Business Edition
- Optional accessory cards

Refer to the instructions included with the software or accessory cards.



This configuration affects the accuracy of the predicted runtime calculations the UPS performs while running on battery power.

Maintenance and Service

Replacing the Battery Module

This unit has two easy-to-replace, hot-swappable battery modules. Replacement is a safe procedure, isolated from electrical hazards. You may leave the external battery pack and connected equipment on during the replacement procedure.

Once the batteries are disconnected the connected equipment is not protected from power outages.

Refer to the appropriate replacement battery user manual for battery module installation instructions. See your dealer or contact APC at www.apc.com or <http://upgrade.apc.com> for information on replacement battery modules.



Be sure to deliver the spent battery(s) to a recycling facility or ship it to APC in the replacement battery packing material.

Service

If the unit requires service do not return it to the dealer. Follow these steps:

1. If the problem persists, contact APC Customer Support through the APC Web site, www.apc.com.
 - Note the model number of the unit, the serial number located on the back of the unit, and the date purchased. If you call APC Customer Support, a technician will ask you to describe the problem and attempt to solve it over the phone. If this is not possible, the technician will issue a Returned Material Authorization Number (RMA#).
 - If the unit is under warranty, repairs are free.
 - Procedures for servicing or returning products may vary internationally. Refer to the APC Web site for country specific instructions.
2. Pack the unit in its original packaging. If this is not available, refer to www.apc.com for information about obtaining a new set.
 - Pack the unit properly to avoid damage in transit. Never use Styrofoam beads for packaging. Damage sustained in transit is not covered under warranty.
 - **Always DISCONNECT THE BATTERY before shipping in compliance with U.S. Department of Transportation (DOT) and IATA regulations.** The battery(s) may remain in the unit.
3. Mark the RMA# on the outside of the package.
4. Return the unit by insured, prepaid carrier to the address given to you by Customer Support.

Warranty Information

Limited Warranty

American Power Conversion (APC) warrants its products to be free from defects in materials and workmanship for a period of two years from the date of purchase. Its obligation under this warranty is limited to repairing or replacing, at its own sole option, any such defective products. To obtain service under warranty you must obtain a Returned Material Authorization (RMA) number from customer support. Products must be returned with transportation charges prepaid and must be accompanied by a brief description of the problem encountered and proof of date and place of purchase. This warranty does not apply to equipment that has been damaged by accident, negligence, or misapplication or has been altered or modified in any way. This warranty applies only to the original purchaser who must have properly registered the product within 10 days of purchase.

EXCEPT AS PROVIDED HEREIN, AMERICAN POWER CONVERSION MAKES NO WARRANTIES, EXPRESSED OR IMPLIED, INCLUDING WARRANTIES OF MERCHANTABILITY AND FITNESS FOR A PARTICULAR PURPOSE. Some states do not permit limitation or exclusion of implied warranties; therefore, the aforesaid limitation(s) or exclusion(s) may not apply to the purchaser.

EXCEPT AS PROVIDED ABOVE, IN NO EVENT WILL APC BE LIABLE FOR DIRECT, INDIRECT, SPECIAL, INCIDENTAL, OR CONSEQUENTIAL DAMAGES ARISING OUT OF THE USE OF THIS PRODUCT, EVEN IF ADVISED OF THE POSSIBILITY OF SUCH DAMAGE. Specifically, APC is not liable for any costs, such as lost profits or revenue, loss of equipment, loss of use of equipment, loss of software, loss of data, costs of substitutes, claims by third parties, or otherwise.

APC Worldwide Customer Support

Customer support for this or any other APC product is available at no charge in any of the following ways:

- Refer to the APC Web site to access documents in the APC Knowledge Base and to submit customer support requests.
 - **www.apc.com** (Corporate Headquarters)
Connect to localized APC Web sites for specific countries, each of which provides customer support information.
 - **www.apc.com/support/**
Global support searching APC Knowledge Base and using e-support.
- Contact an APC Customer Support center by telephone or e-mail.
Local, country-specific centers:
go to **www.apc.com/support/contact** for information.

Contact the APC representative or other distributor from whom you purchased your APC product for information on how to obtain local customer support.

Entire contents copyright 2005 American Power Conversion Corporation. All rights reserved. Reproduction in whole or in part without permission is prohibited.

APC, the APC logo, Smart-UPS, and PowerChute are trademarks of American Power Conversion Corporation. All other trademarks, product names, and corporate names are the property of their respective owners and are used for informational purposes only.