

Overview

HP Moonshot-4QSFP+ Uplink Module

The HP Moonshot system's modular design dramatically simplifies and future-proofs your datacenter for a variety of workloads. The HP Moonshot-4QSFP+ Uplink Module, along with the HP Moonshot-180G Switch Module, provides the Ethernet networking functionality for the HP Moonshot 1500 Chassis. Each chassis supports up to two Moonshot-4QSFP+ Uplink Modules which can be configured for redundancy or traffic isolation. Each uplink module delivers 160 GbE of bandwidth to connect the HP Moonshot system to an external network.

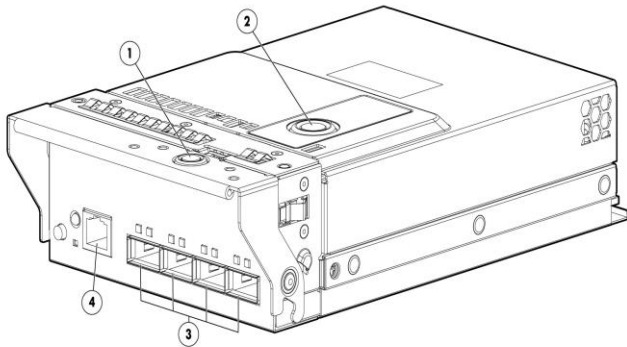

Figure 1 Moonshot-4QSFP+ Uplink Module Components

1. Release Button - Chassis
2. Release Button - Top Lid
3. Four (4) QSFP+ ports
4. Serial console port

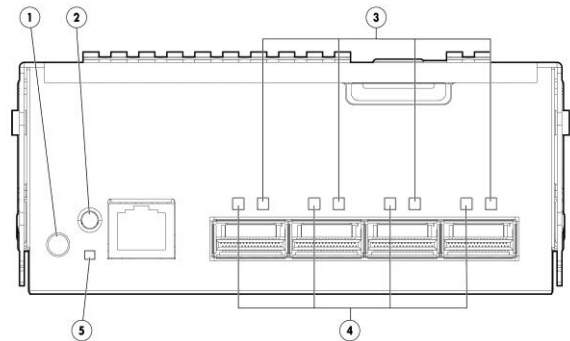

Figure 2 Moonshot-4QSFP+ Uplink Module buttons and LED

1. UID LED/button
2. Health LED
3. Activity LED
4. Link LED
5. Reset button

Models

HP Moonshot-4QSFP+ Uplink Module Kit

704652-B21

NOTE: Must order one of each the Uplink Switch Modules per chassis.

NOTE: For ordering the HP Moonshot-4QSFP+ Switch Module, please see Step 1 of the Configuration to Order section of the HP MoonShot System QuickSpecs:

http://h18000.www1.hp.com/products/quickspecs/14757_div/14757_div.html

Standard Features

Standard Features

- QSFP+ ports support either 40Gb or 10Gb depending on module inserted
- Serial port for out-of-band management
- Link connectivity and activity LEDs
- UnitID (UID) LED / Button for serviceability
- Reset button

Compatibility

- HP Moonshot Chassis** HP Moonshot 1500 Chassis
NOTE: Please see the QuickSpecs for Technical Specifications and additional information:
http://h18000.www1.hp.com/products/quickspecs/14757_div/14757_div.html
(Worldwide)
- HP ProLiant Servers** HP ProLiant m700 Server
NOTE: Please see the QuickSpecs for Technical Specifications and additional information:
http://h18000.www1.hp.com/products/quickspecs/14737_div/14737_div.html
(Worldwide)
- HP Moonshot Switch Modules** HP Moonshot-180G Switch Module
NOTE: Please see the QuickSpecs for Technical Specifications and additional information:
http://h18000.www1.hp.com/products/quickspecs/14731_div/14731_div.html
(Worldwide)

Service and Support

Service and Support

HP Technology Services for Moonshot

Capitalizing on the Moonshot 1500 System requires a service partner who understands your increasingly complex business technology environment. That's why it makes sense to team up with the people who know HP infrastructure hardware and software best - the experienced professionals at HP Technology Services.

HP is pleased to include full software support for Ubuntu Linux as part of your Moonshot chassis purchase. For chassis supporting revenue-generating or production level workloads, consider purchasing a level of support that matches your requirements.

Protect your business beyond warranty with HP Care Pack Services

HP sells support in easy-to-buy, preconfigured packages with the combination of services, coverage and duration to fit your needs and budget. With Moonshot, we are introducing a new, simpler set of services. Simply choose the service level that best fits the criticality of your hardware.

HP Foundation Care

HP introduces new Foundation Care services for HP Moonshot and software. The Moonshot 1500 Care Pack services cover the Moonshot 1500 Chassis and the Moonshot servers with one single Care Pack SKU. Entitlement of support requires the customer to provide the 1500 chassis serial number. All HP components structured to the Moonshot System are covered by Care Pack services inclusive of switches, power supplies, and fans. HP Foundation Care services include hardware support, basic software support and collaborative call handling for software questions related to industry leading operating systems and software. For a complete list of software products covered, refer to: www.hp.com/services/collaborativesupport.

Full software support, including call management and ownership thru to resolution is available for select third party software. As stated earlier, support for Ubuntu software is included in the purchase of your Moonshot chassis.

HP Datacenter Care

HP Datacenter Care offers you a flexible, tailored, relationship-based approach to support the most demanding data centers handling the demands of hyperscale computing. This is an environment level service, purchased once to support your Moonshot environment. Other equipment may be included in this agreement for holistic datacenter coverage. With HP Datacenter Care, you still have the choice of HP Foundation Care reactive support which you purchase with each chassis.

HP Datacenter Care is flexible enough to deliver exactly what you need in one relationship. All Datacenter Care support is tailored to your needs, based on our experience with hyperscale customers:

- Assigned account team, led by an account support manager (ASM) who knows your business and your IT environment and is responsible for the quality service delivery and experience.
- Enhanced call handling for the best call experience with rapid escalation and incident resolution through the HP Hyperscale Center of Excellence
- Proactive and reactive support, configured to deliver the level of support needed by the different data center components and meeting both service-level agreement (SLA) and cost targets

Then add on other services that are tailored to your specific needs, including:

HP Self-Service Spares Service answers the question: What do you do when you need parts? We can set it up so that you get spare parts onsite through our automated self-service spares. You simply go to the part of your data center where the parts live, scan them out, scan in the broken one, and you're done. We maintain your inventory of good spares, so that what you need is ready to go when you need it. And we provide monthly service excellence reports illustrating onsite inventory performance.

Service and Support

To obtain further information or to order HP Datacenter Care Service as described above, contact a local HP sales representative. Please see the Additional Options section of this QuickSpecs for additional information.

HP Moonshot Installation & Startup Service

HP Installation and Startup Service for the Moonshot System provides for the installation of one system and its associated Moonshot servers and network switches, as well as operating system deployment and basic configuration of OS network parameters to establish network connectivity

In response to the needs of the majority of HP Moonshot System customers, this fixed-price/fixed deliverable service targets new hardware installation and software deployments for the 1500 infrastructure. For more advanced installation, configuration, and integration requirements, custom deployments are available through a customized Statement of Work. . Please see the Additional Options section of this QuickSpecs for additional information.

For more information on HP Services, contact any of our worldwide sales offices or visit one of the following websites:

HP support services: www.hp.com/services/alwayson

HP Care Pack services: www.hp.com/services/carepack

Recommended HP Care Pack Services for your HP product

Optimized Care

3-Year HP Foundation Care Call to Repair

This is HP's highest level of reactive support giving you our commitment to have the hardware operational within six hours of opening the call with us. This service level includes hardware coverage plus software diagnosis support with collaborative call management for a broad spectrum of third party software products including O/S and hypervisors.

<http://h20195.www2.hp.com/v2/GetPDF.aspx/4AA4-8877ENW.pdf>

Standard Care

3-Year HP Foundation Care 24x7

This service level provides consistent, reliable reactive support with the broadest coverage window which is recommended when maintenance must be performed outside business hours. Calls may be opened 24x7. Should an onsite visit be needed, our commitment is to respond onsite within four hours. Software call back commitment is two hours.

<http://h20195.www2.hp.com/V2/GetPDF.aspx/4AA4-8877ENW.pdf>

Basic Care

3- Year HP Foundation Care Next Business Day

This service level provides the most economical support coverage and is designed for non-revenue impacting systems. Calls may be opened 24x7. Should an onsite visit be needed, our commitment is to respond onsite the next business day. Software call back commitment is two hours, during regular business hours.

For more information on HP Care Pack services, contact any of our worldwide sales offices or resellers or visit our website at: www.hp.com/go/carepack

Defective Media Retention (DMR) and Comprehensive Defective Material Retention

If your business deals with sensitive or legally protected data, you know that it's not a simple matter to return a defective hardware component, but keeping it conflicts with the terms and conditions of many standard warranty agreements. If you don't return the component, you'll be charged for the replacement part.

HP Foundation Care services are available with defective media retention of failed hard drives and comprehensive defective material retention of those other data-retentive components, such as memory, switches, processors and more. This may be purchased as an optional add-on to your HP Foundation Care service purchase. This service is critical for customers who:

Service and Support

- Need to control and secure their classified, proprietary and confidential data.
- Are subject to current data privacy regulations.
- Want a simpler, more cost-effective solution when choosing not to return a malfunctioning disk drive or other data retentive component.

For more information on our data privacy services, see: www.hp.com/services/dataprivacy.

HP Support Center

HP provides several tools that make it simpler to get help from HP:

HP Support Center is personalized online support portal with access to information, tools and experts to support HP business products. Submit support cases online, chat with HP experts, access support resources or collaborate with peers. Learn more: <http://www.hp.com/go/hpsc>

HP's Support Center Mobile App allows you to resolve issues yourself or quickly connect to an agent for live support. Now, you can get access to personalize IT support anywhere, anytime. HP Support Center are available at no additional cost with a HP warranty, HP Care Pack or HP contractual support agreement.

NOTE: HP Support Center Mobile App is subject to local availability.

For more information

To learn more on HP Moonshot, please contact your HP sales representative

Related Options

QSFP+ Options	HP X140 40G QSFP+ MPO SR4 Transceiver	JG325B
Direct Attached Cables	HP X240 40G QSFP+ QSFP+ 1m Direct Attach Copper Cable	JG326A
	HP X240 40G QSFP+ QSFP+ 3m Direct Attach Copper Cable	JG327A
	HP X240 40G QSFP+ QSFP+ 5m Direct Attach Copper Cable	JG328A
	HP X240 40G QSFP+ to 4x10G SFP+ 1m Direct Attach Copper Splitter Cable	JG329A
	HP X240 40G QSFP+ to 4x10G SFP+ 3m Direct Attach Copper Splitter Cable	JG330A
	HP X240 40G QSFP+ to 4x10G SFP+ 5m Direct Attach Copper Splitter Cable	JG331A
SFP+ Converter	HP QSFP+/SFP+ Adaptor Kit	655874-B21
	NOTE: This turns one 40Gb QSFP+ port into one 10Gb SFP+ port	
	NOTE: Please disregard any compatibility error message while using this adapter	
	NOTE: The transceivers and cables listed above have been qualified and certified to work with this product. Transceiver and DAC cables from any manufacturer will be accepted, but they will not be supported by HP.	
	HP BladeSystem c-Class Small Form-Factor Pluggable 5m 10GbE Copper Cable	537963-B21
	HP C-Series SFP+ to SFP+ Copper 5.0m Direct Attach Cable	AP785A
	NOTE: Equivalent to Cisco 10Gb Short Range Small Form-Factor Pluggable Option	
Serial Console Cable	RJ45 to (F) DB-9 serial console port cable	5188-6699

Technical Specifications

Product Specifications Hardware	Ports	Four (4) 40 Gb QSFP+ uplink ports One (1) RJ-45 Serial Console Port for management	
	Indicators/Buttons	Module health, red/amber/green Module locator (UID), blue (LED & push button switch) Port link indicator, green Port activity indicator, green Recessed push button reset switch	
	Physical Characteristics	Length	5.40 in (13.71 cm)
		Width	8.83 in (24.96 cm)
		Height	2.22 in (5.64 cm)
		Weight	0.963 kg (2.12 lbs)
	Environmental Ranges	Temperature Range	Operating 50° to 95° F (10° to 35° C)
			Non-operating -22° to 140° F (-30° to 60° C)
		Relative Humidity (non-condensing)	Operating 10% to 90%
			Non-operating 5% to 95%
Altitude		Operating 10,000 ft. (3048 m)	
		Non-operating 30,000 ft. (9144 m)	
Power Consumption	Typical	12.5W	
	Maximum	20W	
Safety and Compliance Safety Certifications	Complies with UL 60950-1, CAN/CSA C22.2 No. 60950-1 and EN 60950-1. UL certified. CE Marking RoHS 6/6 compliant		
Emissions Classifications (EMC)	Class A		
Environment-friendly Products and Approach	End-of-life Management and Recycling	<p>Hewlett-Packard offers end-of-life HP product return, trade-in, and recycling programs in many geographic areas. For trade-in information, please go to: http://www.hp.com/go/green. To recycle your product, please go to: http://www.hp.com/go/green or contact your nearest HP sales office. Products returned to HP will be recycled, recovered or disposed of in a responsible manner.</p> <p>The EU WEEE directive (2002/95/EC) requires manufacturers to provide treatment information for each product type for use by treatment facilities. This information (product disassembly instructions) is posted on the Hewlett Packard web site at: http://www.hp.com/go/green. These instructions may be used by recyclers and other WEEE treatment facilities as well as HP OEM customers who integrate and re-sell HP equipment.</p>	

Summary of Changes

Date	Version History	Action	Description of Change:
28-Feb-2014	From Version 1 to 2	Added	A part number was added to the Related Options section.
13-Jun-2014	From Version 2 to 3	Added	SFP+ Converter was added to Related Options.
03-Oct-2014	From Version 3 to 4	Changed	Changes made throughout the QS

© Copyright 2014 Hewlett-Packard Development Company, L.P.

The information contained herein is subject to change without notice.

The only warranties for HP products and services are set forth in the express warranty statements accompanying such products and services. Nothing herein should be construed as constituting an additional warranty. HP shall not be liable for technical or editorial errors or omissions contained herein.