



High Speed HDMI Cable With Ethernet Channel

HDMI Male to Male, Shielded, Black

High Speed Cables deliver high-definition performance.

HDMI has become the standard digital connection, delivering the highest-quality audio and video signal over a single cable. MANHATTAN® High Speed HDMI Cables are designed and carefully constructed to meet the evolving needs of the high-definition marketplace. MANHATTAN High Speed HDMI Cables provide the highest resolution possible at 4K x 2K, an audio return channel, a bandwidth of 10.2 Gbps at 340 MHz. These high-quality cables provide high-definition video and multi-channel, digital audio with increased performance characteristics, greater accuracy and expanded features including Internet connectivity for home entertainment devices using a single HDMI connection.

Model	Length
323192	1 m (3.3 ft.)
323215	2 m (6.6 ft.)

Lifetime Warranty

Strict manufacturing standards ensure the highest quality in all MANHATTAN products. All items carry a full Lifetime Warranty — the strongest quality commitment anyone can make.

Model
323192
323215



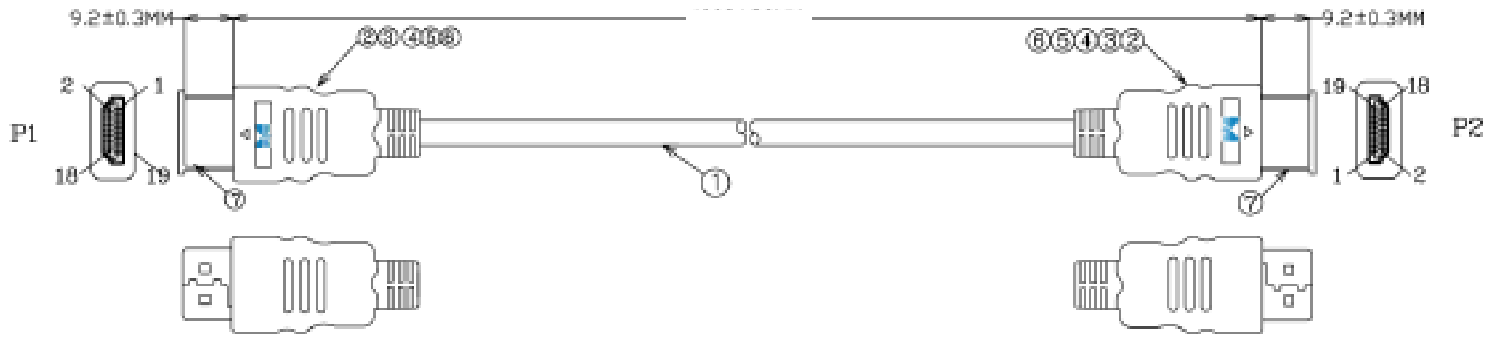

ELECTRICAL TEST:
 1.100% OPEN & SHORT & MIS WIRE TEST
 2.CONTACT RESISTANCE:2 OHM(MAX)
 3.INSULATION RESISTANCE:10M OHM(MIN)
 4.HI-POT TEST:DC 300V/10ms

Pin Assignment

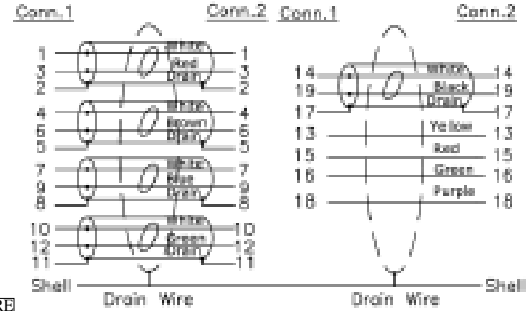

THESE DRAWINGS AND SPECIFICATIONS ARE THE PROPERTY OF MANHATTAN AND SHALL NOT BE REPRODUCED, COPIED OR USED IN ANY MANNER WITHOUT THE PRIOR WRITTEN CONSENT OF MANHATTAN.

NO	QTY	DESCRIPTION	UNIT
7	2	A6-0000015 HDMI COVER TRANSPARENT	PCS
6	2	A10-R075133 BLACK SHRINK TUBE #1.5*10MM	PCS
5	8	A10-R075130 BLACK SHRINK TUBE #2.5*10MM	PCS
4	16	A5-R047001 BLACK 40P PVC	G
3	3	A5-R047011 TRANSPARENT PE	G
2	2	A2-R030042 HDMI M 19P SOLDER TYPE BLACK INSULATION SHELL NICKEL PLATED	PCS
1	1	A4-R001736 UL20276 (7)VL18T*1PR+6AH*1SC+7VL18T*4C+AEB (1)P*1VL12 GD:6.0MM BLACK 1.4V	M

REV.	TOLERANCE		DESCRIPTION	DATE
	INCHES	M/M		
	.X	.015	.30	
	.XX	.010	.10	
	.XXX	.005	.05	

DRAWN BY: Cal		CUSTOMER :	
CHECK BY:		CUSTOMER P/N:	
APPD BY:		SCALE: NONE	DRAWING NO:
		UNIT: MM	REV: A
		DATE: 04.10/09	1/2

Features

- HDMI 19-pin male to HDMI 19-pin male connections
- Ensures the integrity of the signal between HDMI devices
- High-speed, bi-directional networking at up to 100 Mbps
- Supports HD resolutions beyond 1080p and Deep Color
- Compliant with High Speed HDMI specifications
- Up to 10.2 Gbps at 340 MHz bandwidth
- Fully shielded to reduce EMI and other interference sources
- Molded PVC boot
- Lifetime Warranty

Specifications

STANDARDS/CERTIFICATIONS

- UL 20276
- ISO 9002
- RU
- CE

GENERAL

- Bandwidth: 10.2 Gbps
- 340 MHz
- HEC support
- Meets or exceeds existing HDMI standards

CONTACTS

- 2 x HDMI 19-pin male

- Nickel-plated contacts
- Molded PVC boot
- Shielded, aluminum and braided
- 30 AWG connectors

ELECTRICAL

- Current rating: 0.5 A DC
- Withstanding voltage: 300 V DC
- Insulation resistance: 50 MOhms
- Conductive resistance: 2 Ohms
- Thermal plastic casing

PACKAGE CONTENTS

- High Speed HDMI Cable With Ethernet Channel

For more information on MANHATTAN products, consult your local dealer or visit www.manhattan-products.com.



Copyright © MANHATTAN

